

# INLINE 160 TENSIONED MW MOUNTING BRACKET

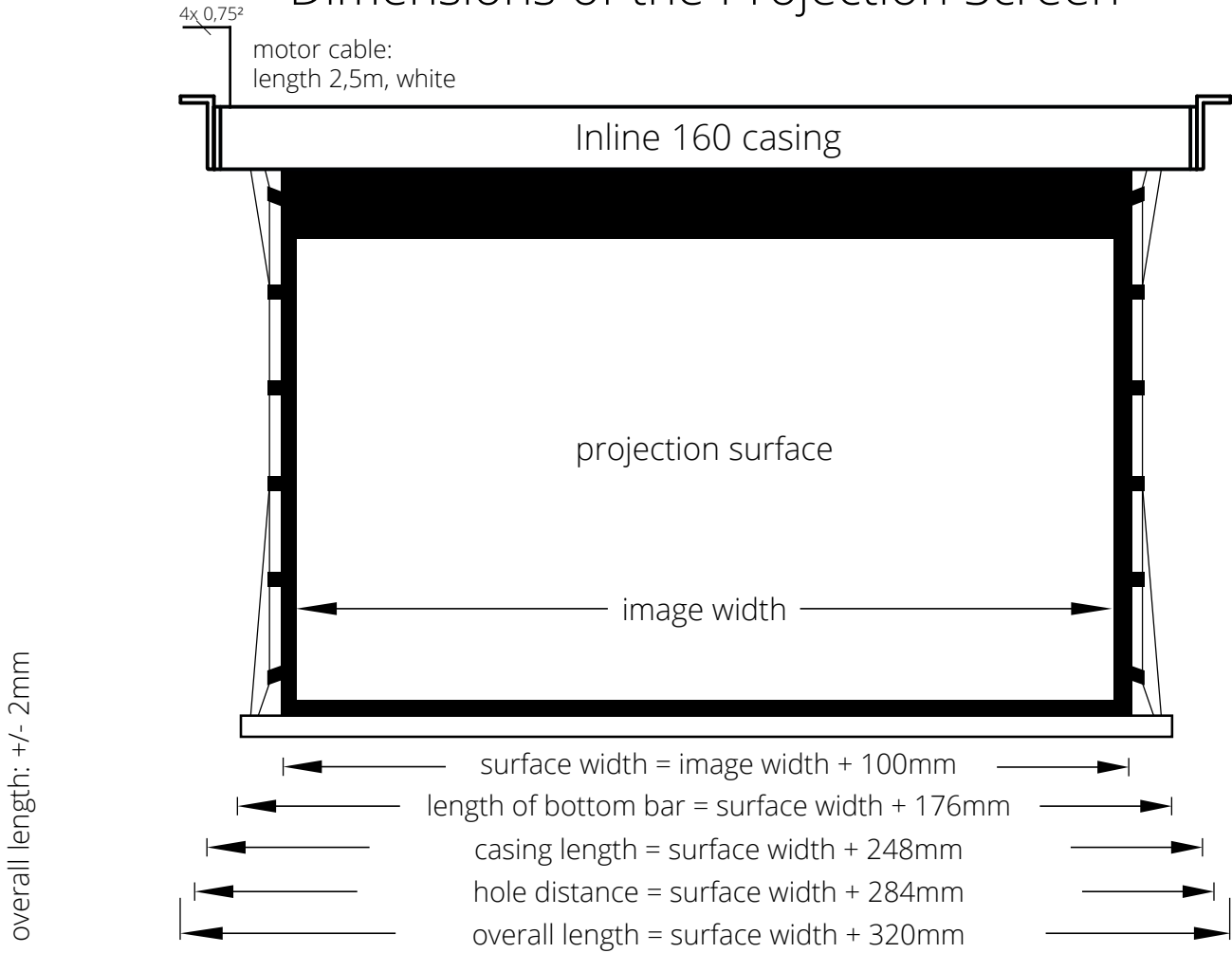

## Dimensions of the Projection Screen



### Cross Section Inline-Casing

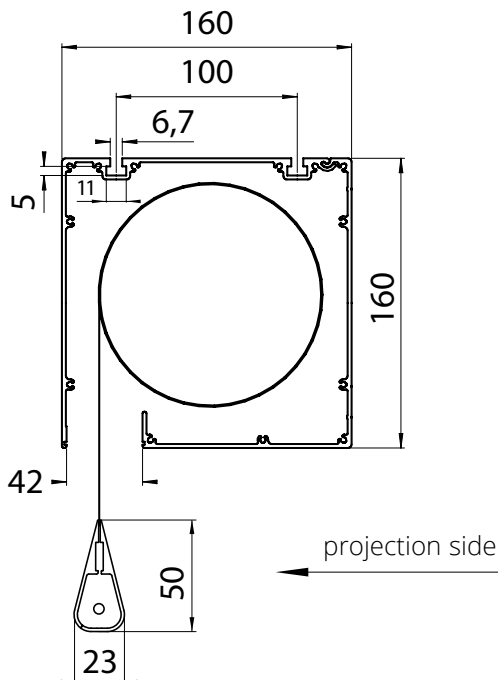

### Universal - Mounting Bracket for wall and ceiling mounting

