

INLINE 125 TENSIONED MW MOUNTING BRACKET

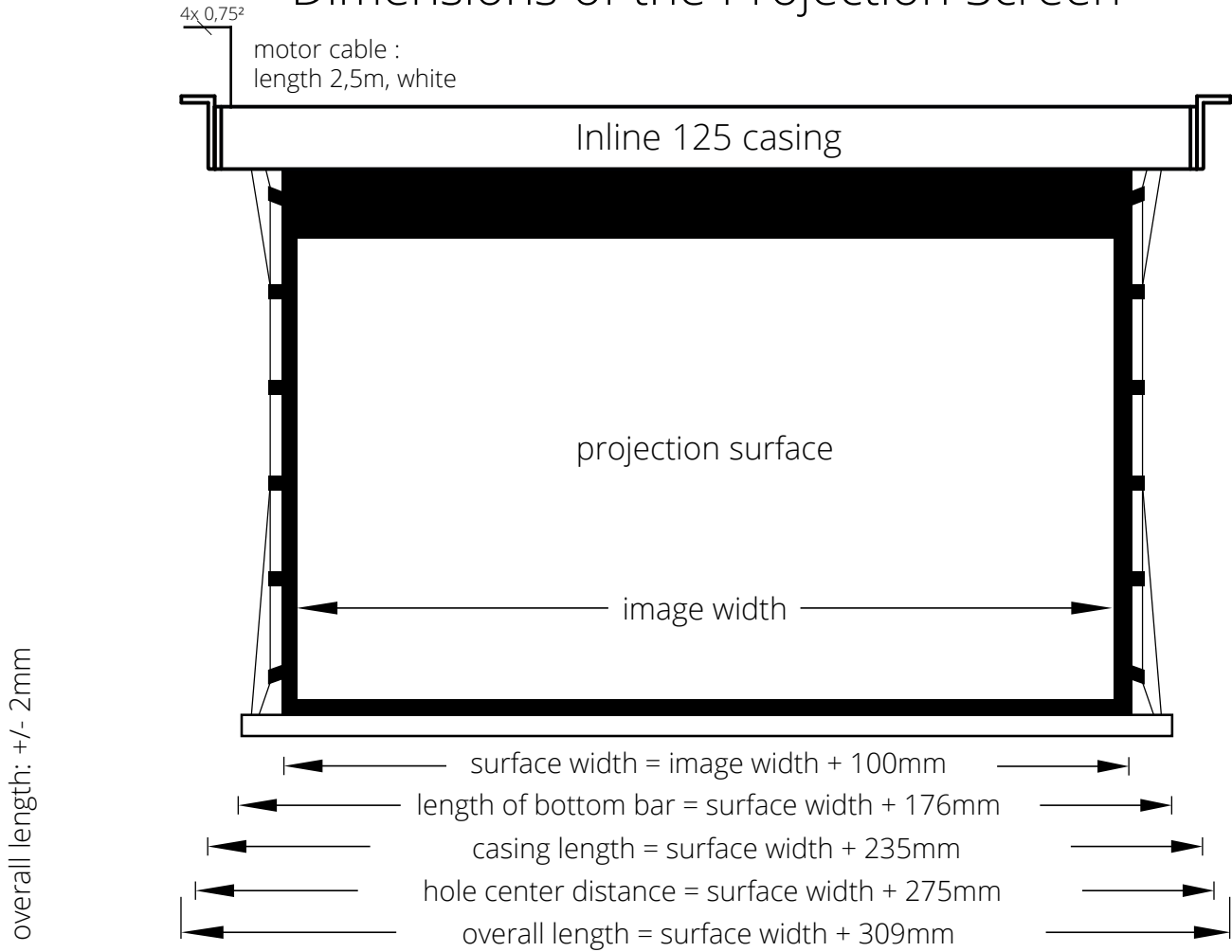

Dimensions of the Projection Screen



Cross Section Inline-Casing

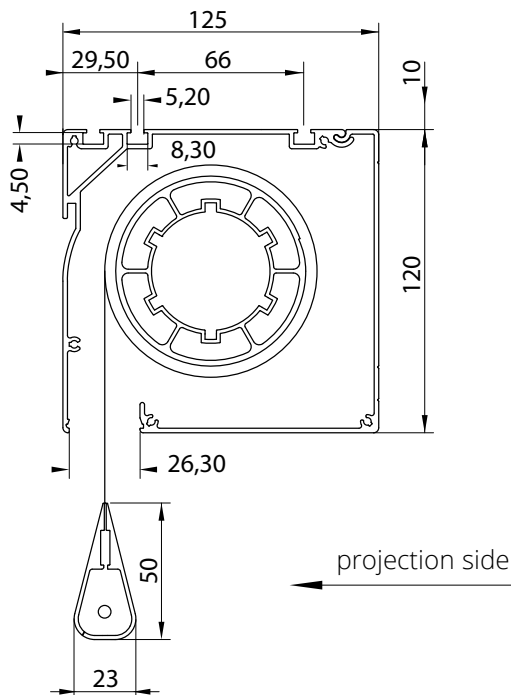

Universal - Mounting Bracket for wall and ceiling mounting

