

INLINE 125 TENSIONED DMP MOUNTING PLATE

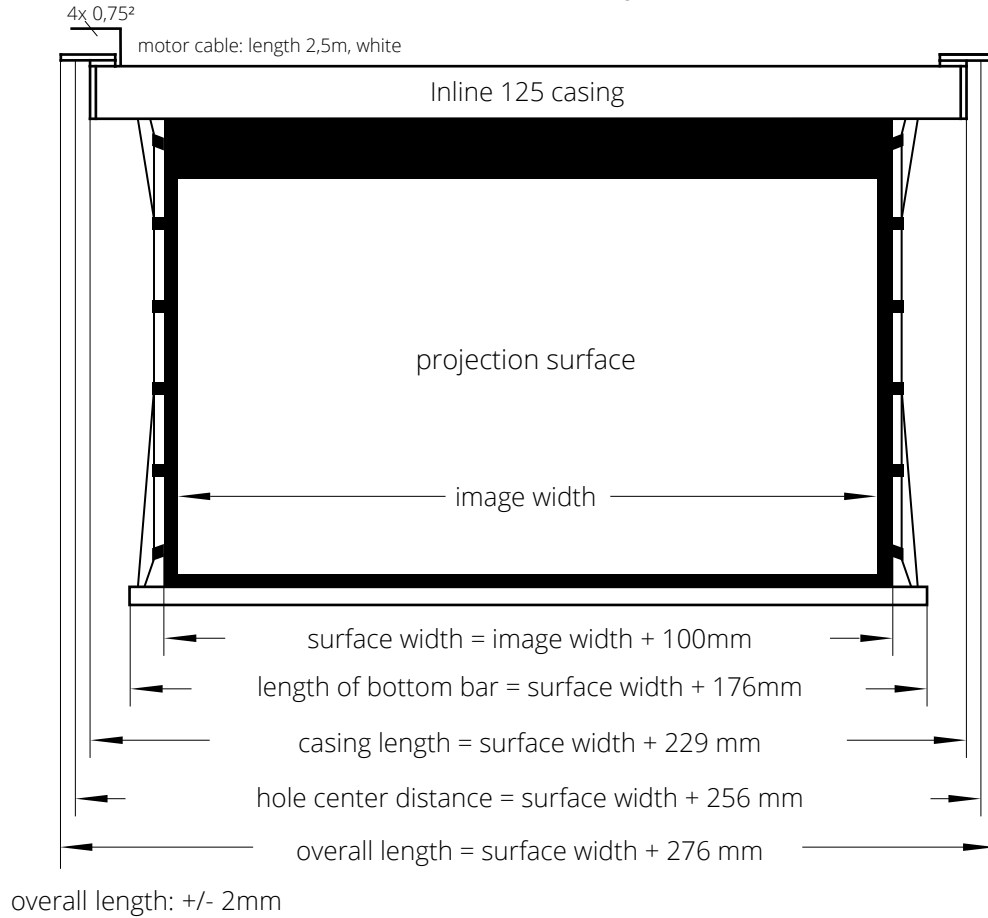

Dimensions of the Projection Screen



Cross Section Inline-Casing

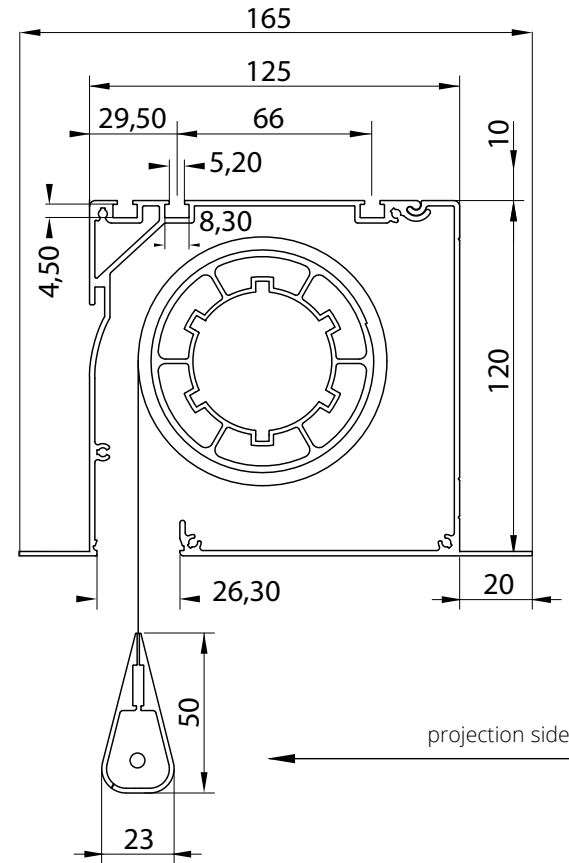

T-slot mounting plate BIZ-DMP/090/125

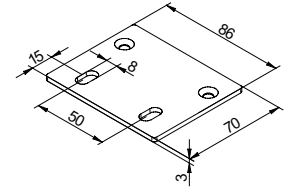

T-slot mounting plate BIZ-MSAD/DMP/090/125 for mounting kit

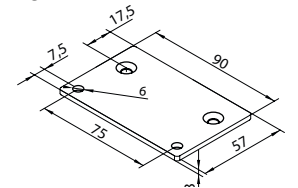

Ceiling plate BIZ-MSAD/DMP/090/125 for mounting kit

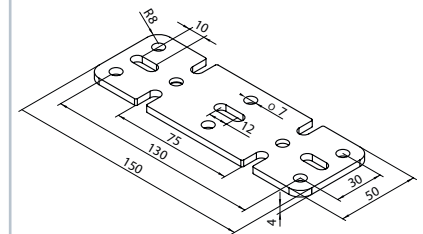

BIZ-DMP/090/125 Mounting Plate Assembly

The mounting plate is bolted together with the spacer profile onto the top of the casing by countersunk screws and square nuts, inserted into the T-slots. The C-shaped spacer profile can be rotated by 180°, according to the motor connection cable laying.

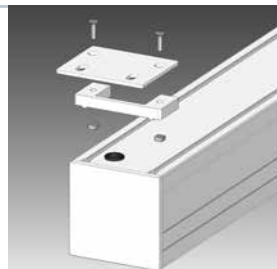

BIZ-MSAD/DMP/090/125 Mounting Set for Suspended Ceiling

A variation of the mounting plate, which can be combined with a mounting set for suspended ceiling, is available for special mounting requirements. e.g.: Screen is completely integrated into the ceiling (Note: Provide service flap) The mounting set enables a continuous adjustment of the mounting height by thread rods (100 cm).

