

## Abmessungen der Projektionswand

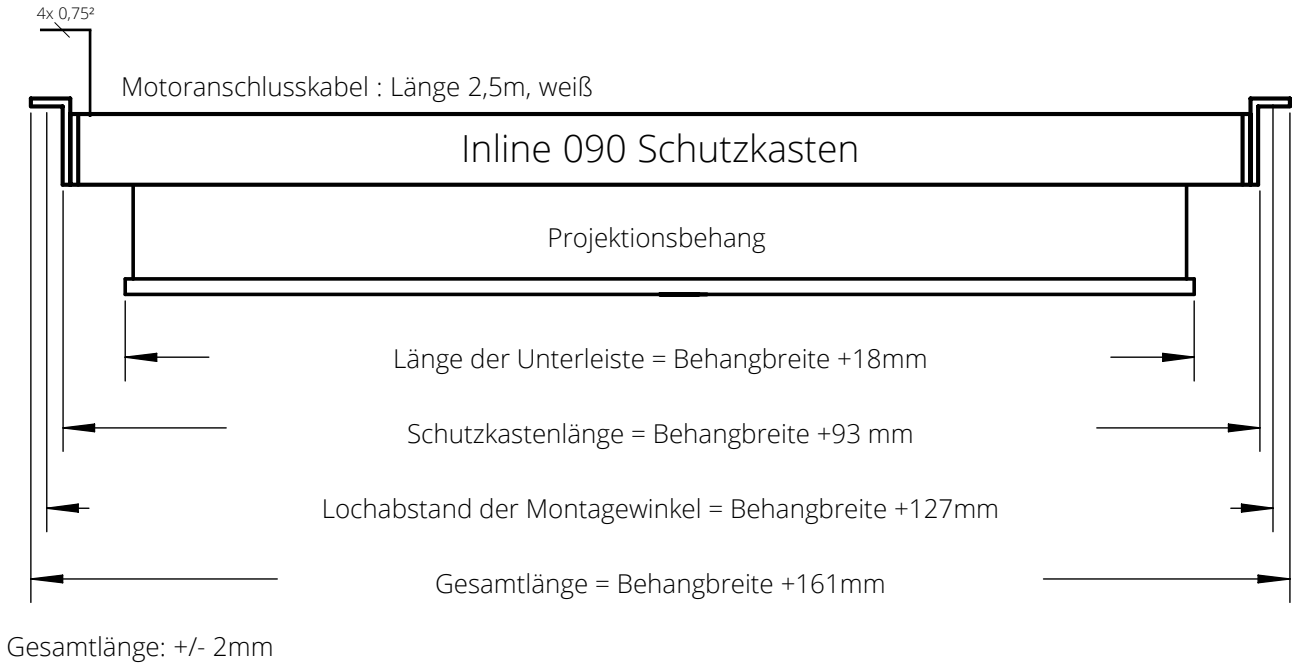

## Querschnitt Inline-Schutzkasten

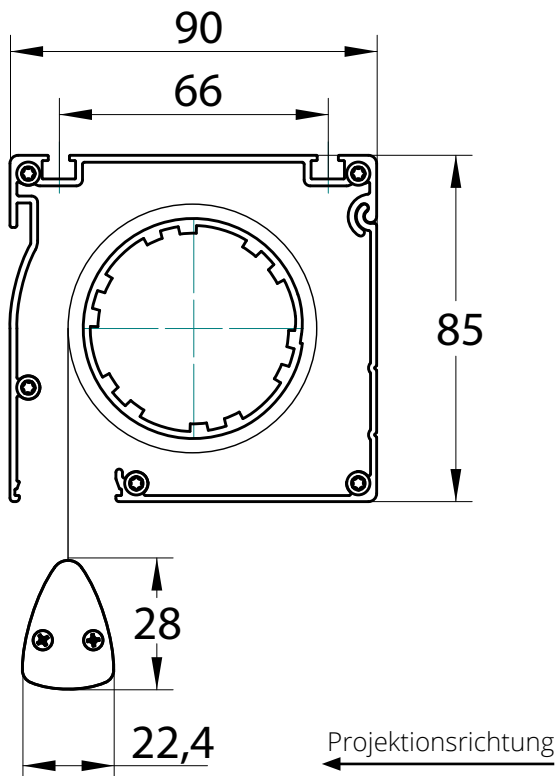

## Universal Montagewinkel

für Wand und Deckenmontage

