

## Abmessungen der Projektionswand

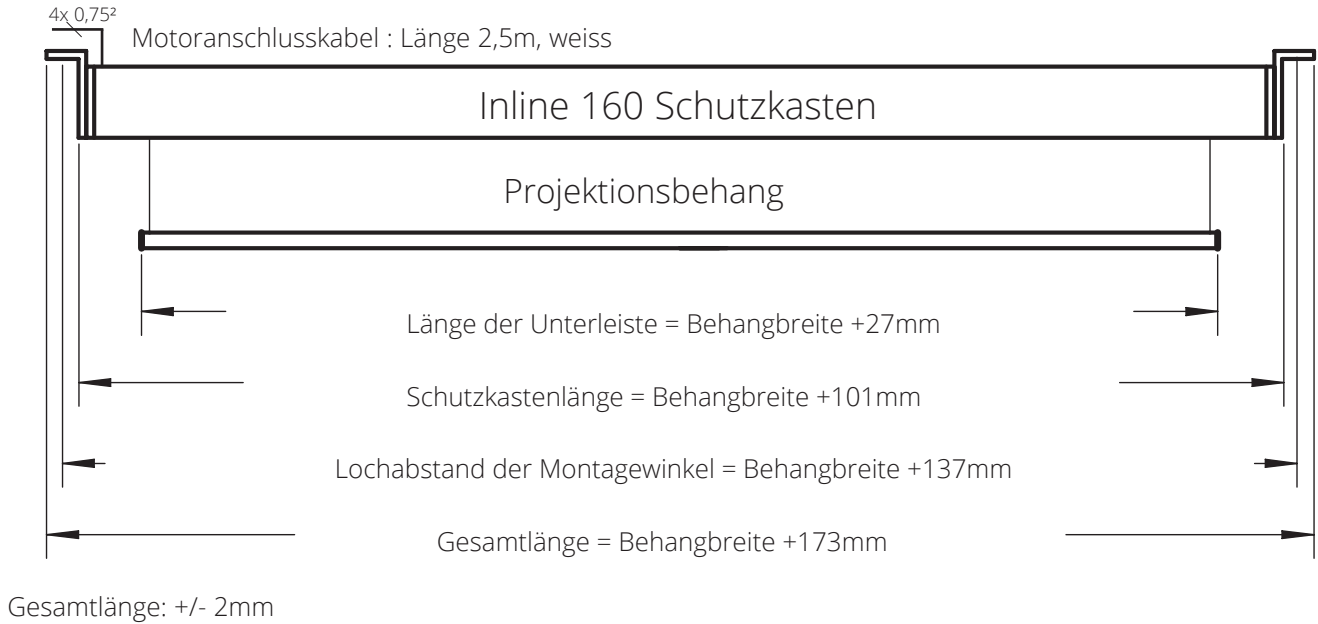

## Querschnitt Inline-Schutzkasten

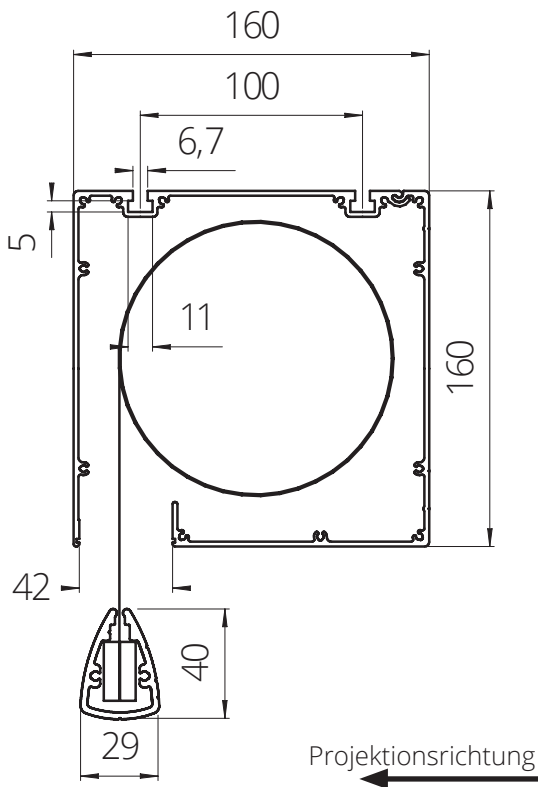

## Universal - Montagewinkel

