

INLINE 125 EBR CRANK CEILING INTEGRATION

Dimensions of the Projection Screen

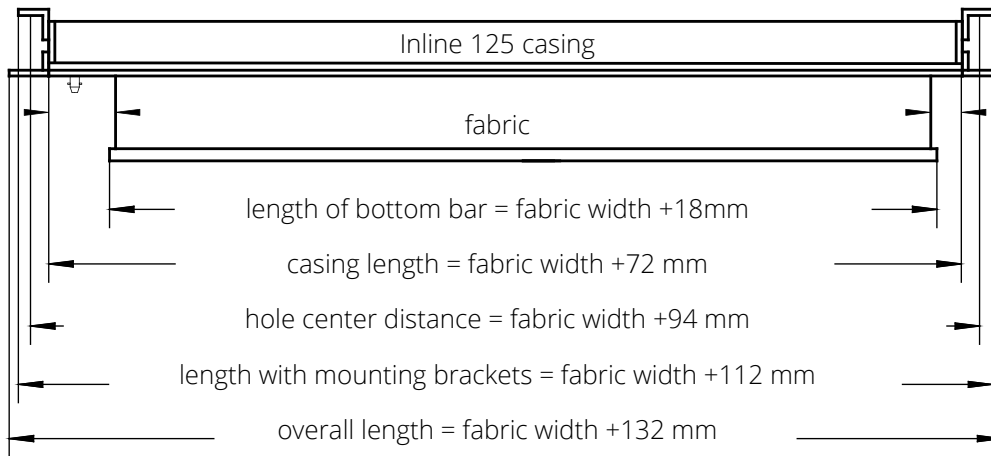

overall length: +/- 2mm

Crank length:

148 cm (fabric height under 220 cm); 167 cm (fabric height above 220 cm); custom length on request

All projection screens in system Inline are available as projection screens for ceiling integration. The clip-brackets on both sides of the screen are detachable to allow convenient access to the screws for mounting and servicing. Mounting and dismantling of the projection screen can be done without service flap.

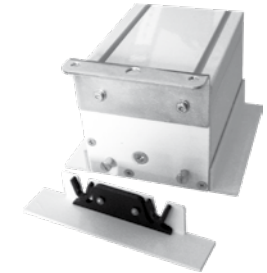

RECESS FOR SUSPENDED CEILING:

In case of subsequent mounting of the projection screen into a suspended ceiling, a recess according to the sketch below has to be made.

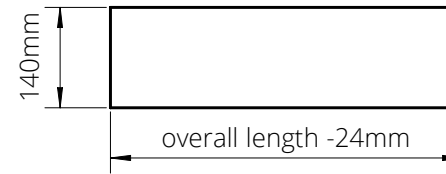

Cross Section Inline-Casing

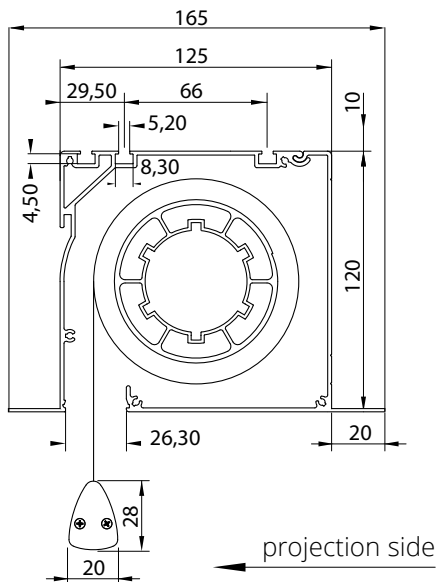

Clip Bracket and Mounting Bracket

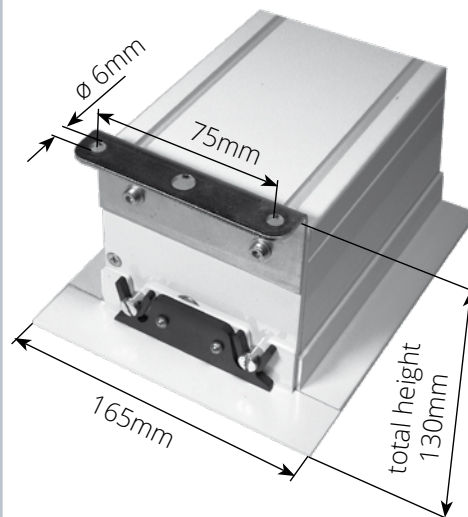

BIZ-MSAD/125

Inline Mounting Set for Suspended Ceiling

The Mounting Set - the perfect supplement for projection screens for suspended ceilings. Thread rods (100cm) enable a continuously adjustment to the ceiling level.

Ceiling plate for mounting set BIZ-MSAD/125

