

SHIFT-LEG ADAPTION INSTRUCTION FOR VARIO SCREENS

INDEX

GENERAL.....	3
STANDARDS, REGULATIONS AND TECHNICAL SPECIFICATION	3
SAFETY	3
OPERATION, MAINTENANCE AND SERVICE	6
WARRANTY	7
VARIO FRAME MODIFICATION.....	8
HEIGHT, LEG LENGTH AND ADAPTER POSITIONING.....	9
ADAPTER IN THE BASIC FRAME	10
THROUGH HOLE 6MM	11
EXTENSION HOLE 8MM	11
ADAPTER MOUNTING.....	12

GENERAL

STANDARDS, REGULATIONS AND TECHNICAL SPECIFICATION

This projection screen is in accordance with the safety regulations in DIN standard 19045 and DIN 56950. The screen fabric is comply with DIN 4102 part 1 and the specifications of the according data sheet. For the technical details and projection-specific material parameters please refer to the corresponding product data sheet: www.AVstumpfl.com/projectionmaterials

Detailed data of frame components, legs and projection surface can be found on the type labels on each component and on the labeled soft bags, roller bags or flight cases.

SAFETY

GENERAL INFORMATION FOR THE MANUAL AND SAFETY

This operating manual forms part of the projection screen system and enables a safe and efficient operation. The safety section provides information about important safety aspects for the protection of persons, frame and projection materials. Task-related warnings/notes are also contained in the individual chapters. Read instructions through completely before proceeding and keep for future reference. You can find manuals electronically on our website: www.AVstumpfl.com/downloads

PACKAGING MATERIAL

WARNING

Danger of suffocation!

- Keep packaging material and foils away from children.
- Do not let children play with packaging material.



NOTICE

Unpack without cutter or any other sharp tool to avoid damaging of the projection screen. Remove packaging materials by hand. Unpack projection surface after assembling of the frame.



SET UP-ASSEMBLY

MECHANICAL HAZARDS



Danger of injury due to improper assembly. Make sure all frame parts assembled correctly and all hinges and joints are locked before raising screen to standing position. Falling parts can cause severe injury or death!

NOTICE

Projection surface damage in case of faulty assembly or set up. Make sure all frame parts assembled correctly and all hinges and joints are locked before one unfold and attach the projection surface.

FRAME AND LEG COMPONENTS



Foldable snap joints, corner hinges and plug-in connections can lead to injury to the hands (body parts). Please be careful not to pinch your fingers!

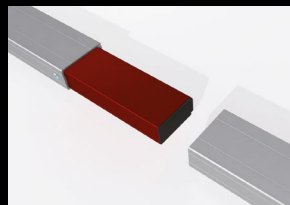
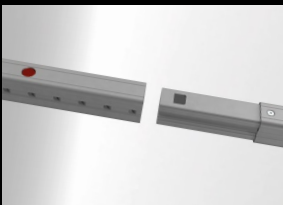

FALLING OVER

WARNING

Falling over of a projection screen can cause severe injury or death!
To avoid falling over:

- Make sure that the projection screen is in level.
- Mind the maximum set-up height of the legs
- Prevent air draft
- Use additional weights on the base profile of the leg to gain higher stability.
- Use suspension points (e.g.: EasyFly) according to the overall system weight for additional safeguarding.
- Do not put additional load on the screen frame!
- Do not use outdoors!

⚠ WARNING

Mobile projection screens are developed for indoor use only.
 Failure to follow warning may result in personal injury due to unforeseen acts of nature.
 Any damage and consequential damage caused by outdoor use is not covered by warranty.

BASIC SAFETY REQUIREMENTS

Basic safety requirements for „flying“ projection screens and wall- or ceiling mounting!
 If persons are able to stand under the loads, fastening points and slings must not be loaded more than half the value of the load bearing capacity stated by the manufacturer.
 When planning the event or production, not only dead loads but also dynamic forces, potential breakdown loads and additional loads during operation, as well as during assembly and dismantling must be taken into account.

Observe the local safety regulations!

FLYING SCREEN

If a modular projection screen is used as a “flying” (free hanging) screen, then all plug-in and clamp connections must be secured against becoming loose and falling.
 It is not allowed to use the projection surface holding the frame parts in position!
 Falling parts can cause severe injury or death!
 Please make sure that all components are secured safely before raising screen to standing position and lifting. Use the necessary number of suspension points (e.g.: EasyFly) according to the overall system weight. A second/auxiliary safeguarding system is mandatory (e.g. steel rope catch)
 Please follow the detailed instruction in the manual.

⚠ WARNING

Falling parts

It is not allowed to use the projection surface holding the frame parts in position! Falling projection screens or parts can cause severe injury or death!

WALL- OR CEILING MOUNTING

Before mounting, make sure that the wall or ceiling, as well as the fixing points meet the safety requirements of the local standards and the required load can be borne.

⚠ WARNING

Falling parts

Danger of injury due to improper disassembly.
 Falling parts can cause severe injury or death!

⚠ CAUTION

Please be careful not to pinch your fingers!

Beware of pinch points.

DISASSEMBLY

For disassembly the same safety instructions apply as for assembly and set up. Bring down a projection screen with the appropriate number of people to avoid falling over of the screen.



Falling parts can cause severe injury or death!

OPERATION, MAINTENANCE AND SERVICE

FRAME ELEMENTS, LEGS AND ACCESSORIES

The frame elements, legs and additional elements are maintenance-free.

PROJECTION SURFACE

FOLDING AND STORAGE

The projection surface is packed into a separate lined soft bag to avoid any damage by the frame parts, bleaching and discoloration.

Store the projection surface cleaned and dry at room temperature only!

Identical to the delivery condition, first halve and fold the surface with the projection side inwards on the shorter side in order to avoid soiling and damage to the surface.

The surface must be folded in such a way that the reinforced black border with the caps is on top of each other on all sides. Incorrect storage can damage and discolor the surface and is not covered by the guarantee. When folding the projection surface insert the enclosed foamed plastic foil between snap buttons and surface to avoid permanent marks.

NOTICE

Additionally, following instructions have to be adhered to:

- Do not allow the projection surface to get in contact with sharp objects!
- Do not bring printed and coloring objects (instructions, magazines, etc.) in contact with the surface!
- Do not write on the projection surface!
- Colors penetrate the projection surface and cannot be cleaned anymore!

COLD BREAK

A projection foil must never be stored or transported below 5° C. There is a risk of a cold break! The film becomes very brittle and splinters like glass! When transporting the projection surface at low temperatures do not unfold the surface unless it has reached its full elasticity at room temperature. Otherwise there is the risk of cold break of the projection screen.

The ideal temperature range for assembling folding screens to prevent damaging the surface is 54°-82° F (12°-28° C). Assembling below recommended temperatures may damage surface and void warranty

CLEANING OF THE PROJECTION SURFACE

Use a white clean cotton cloth saturated with clear water (optionally mild soap water) and gently wipe the area in one direction (no circular motion). Wipe dry with another cotton cloth.

To clean a stubborn stain, use methylated spirit and follow the same procedure.

Clean rear projection surfaces in case of imperative only!

WARRANTY

The warranty period for production deficiencies is 5 years for the frame elements and 24 months for the projection surface.

NOTICE

Mobile projection screens are developed for indoor use only.
Any damage and consequential damage caused by outdoor use is not covered by warranty.

The general terms and conditions are available at www.AVstumpfl.com/agb

LIMITATION OF LIABILITY

All the details in this manual were compiled in consideration of the standards and legal regulations applicable at this time, as well as the experience of the manufacturer and qualified staff. The manufacturer accepts no liability for damage to persons or things (projection screen, other devices, goods, etc.) resulting from:

- Non-observance of the manual and the regulations/safety instructions contained therein.
- Failure to comply with the local safety regulations.
- Inappropriate use (misuse).
- Use of unauthorized and non-trained staff.
- Unauthorized equipment conversions and technical modifications by the operator himself.
- Use of spare parts not approved by the manufacturer.
- Typesetting and print errors.

Failure to observe the above points will invalidate the warranty claims.
Technical specifications are subject to change without notice.

The local regulations and safety regulations and the essential safety requirements apply for the use of this projection screen.

DISPOSAL

At the end of its lifetime this product must not be disposed of with normal household waste but needs to be taken to a collection site for recycling.
Separate disposal of the product makes an important contribution towards environmental protection.
Frame components and legs are made of aluminum and steel.
The projection material is PVC vinyl.
Contact your local disposal company for the address of a collection center.

SUBJECT TO MODIFICATIONS, ERRORS EXPECTED !

VARIO FRAME MODIFICATION

ADAPTION FOR SHIFT LEGS

All VARIO projection screens that are already in use can be easily adapted subsequently for use with SHIFT legs. You just have to drill a hole and attach an adapter onto the plug-in profiles.

As an option, we offer a factory modification with subsequent attachment of additional insert nuts with spacers in order to be able to mount the frame adapter for SHIFT-legs.

Sales article: BVZ-MOD / HM / SHIFT

Projection screen modification VARIO, sleeve nut M6 + countersunk screw M6x30mm

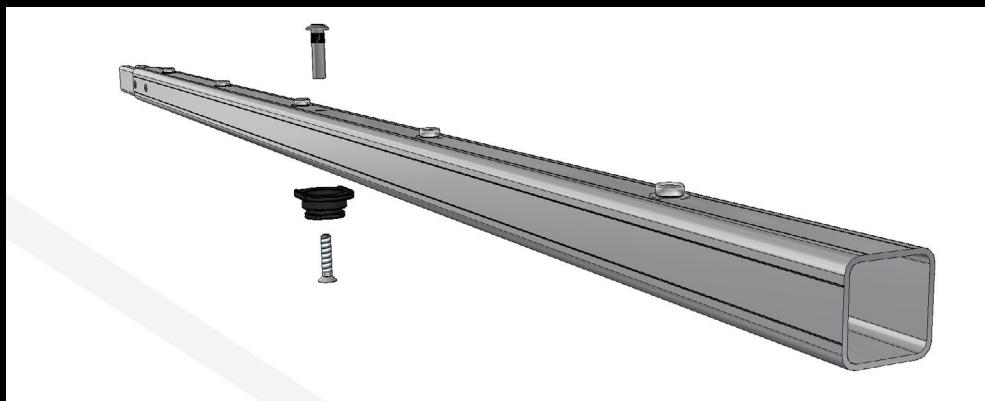

(Picture Vario 32)

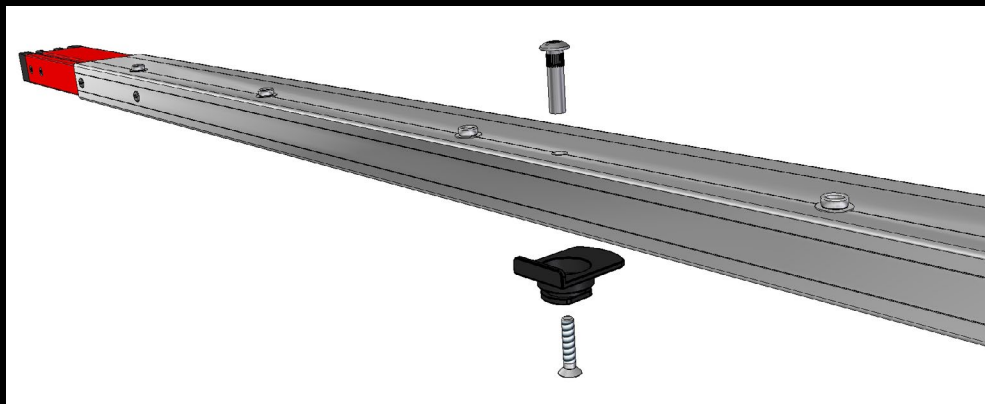

(Picture Vario 64)

HEIGHT, LEG LENGTH AND ADAPTER POSITIONING

Determination of the adapter position and leg length according to the frame height and the desired setup height (s).

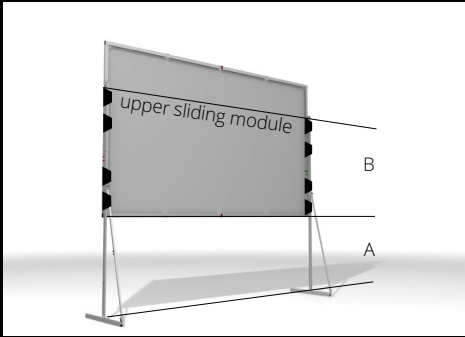

(Picture Vario 64)

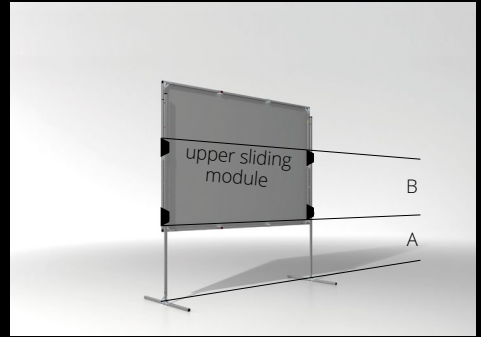

(Picture Vario 32)

1. SETUP HEIGHT:

Choice of setup height A

For maximum installation heights, please refer to the corresponding data sheet for the type of leg used.

2. LEG LENGTH:

Select the leg length according to the desired setup height.

Leg length must be higher than A+B (Picture above)

▶ = positioning of frame adapters

A = setup height B = bottom frame corner to upper sliding module

3. ADAPTER POSITIONING

Make sure that the position for the frame adapter is chosen so that the frame parts can be assembled unhindered, the sliding modules can be mounted and the projection surface can be attached.

The following minimum clearances must be observed:

3.1. Distance from fastening points of the projection surface (front of profile): A= 25mm (1")

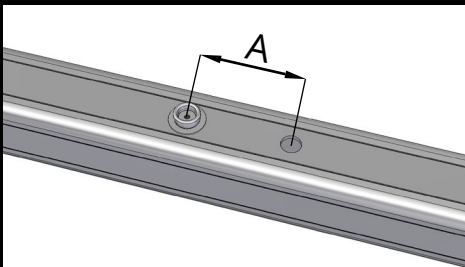

(Picture Vario 32)

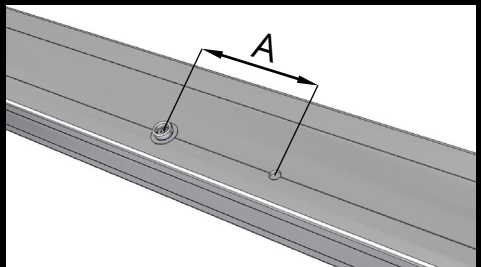

(Picture Vario 64)

3.2. Distance from the open profile end (B):

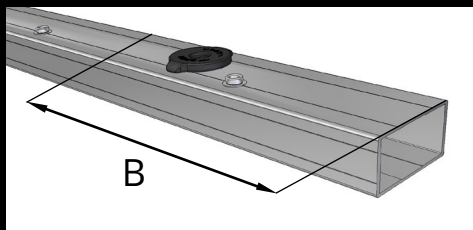
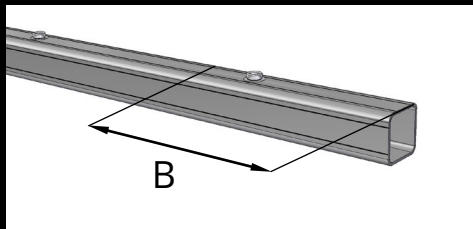

VARIO 32: 135mm
 VARIO 64: 170mm
 VARIO LOCK 64: 170mm
 VARIOCLIP 64: 170mm

3.3. Distance from the profile end (side of plug-in profile):

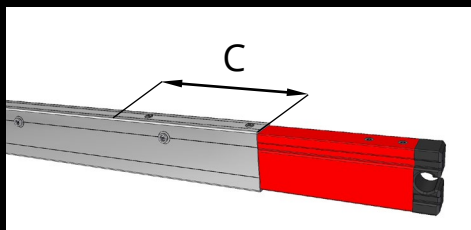
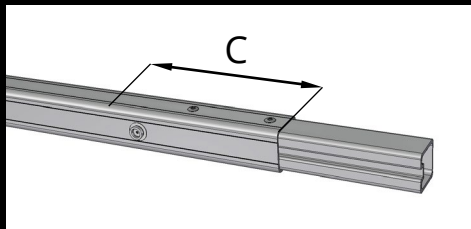

VARIOCLIP LOCK 64: 170mm
 VARIOCLIP CLAMP: 170mm

ADAPTER IN THE BASIC FRAME

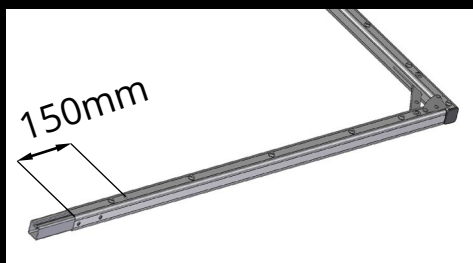

(Picture Vario 32)

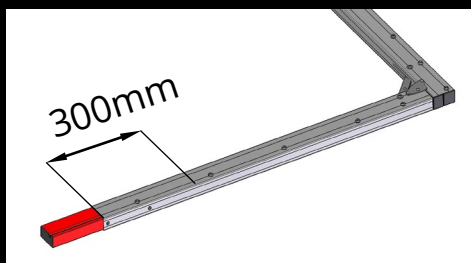

(Picture Vario 64)

With low frame heights (less than 350cm) it may be necessary to use an adapter in the upper corner elements of the basic frame. Recommended distance from the end of the profile:

VARIO 32: 150mm
 VARIO64: 300

THROUGH HOLE 6MM

First select the position according to the specified minimum distances (see page 9-10). The hole must be drilled at a distance of 16mm from the outer edge of the profile. For a perfectly fitting, vertical drilling, we recommend using a column drill with a vice. Optionally mark the hole on each side accordingly and drill only one wall thickness.

VARIO 32: hole exactly in the middle of the profile (16mm)

VARIO64 hole 16mm from the outer edge of the profile, exactly on the first outer decorative groove.

⚠ CAUTION Risk of injury!

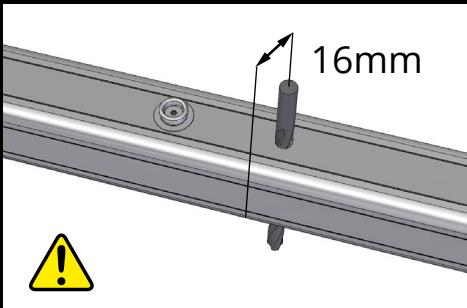

(Picture Vario 32)

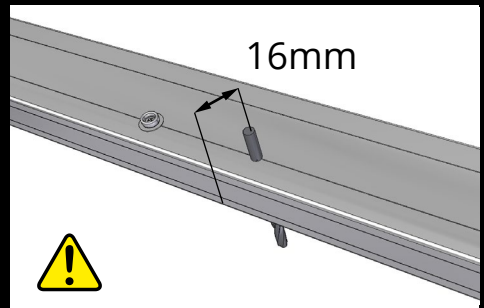

(Picture Vario 64)

EXTENSION HOLE 8MM

Extension hole from 6mm to 8mm on the front of the profile (side of the surface attachment)

⚠ CAUTION Risk of injury!

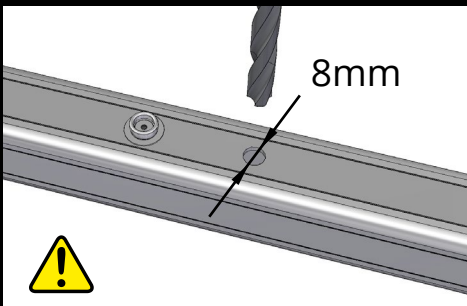

(Picture Vario 32)

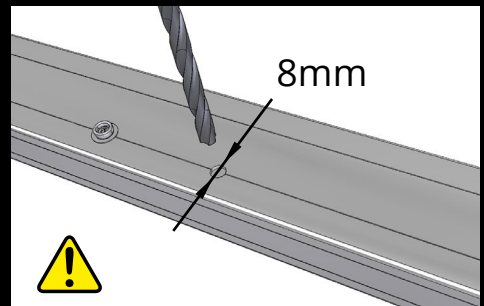

(Picture Vario 64)

ADAPTER MOUNTING

Insert the M6 sleeve nut and mount the frame adapter.
A Phillips screwdriver and a 4mm hex key are required.

⚠ CAUTION Beware of pinch points!

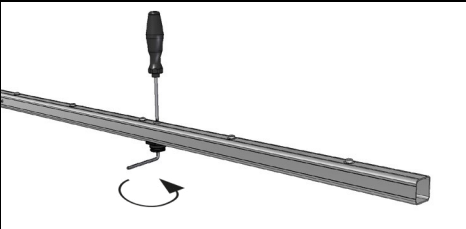
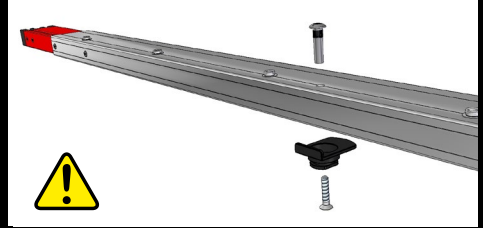
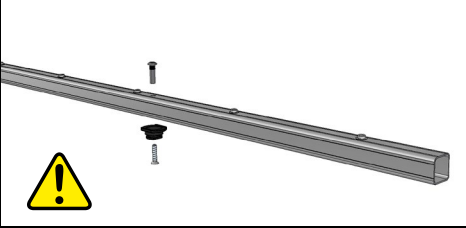

(Picture Vario 32)

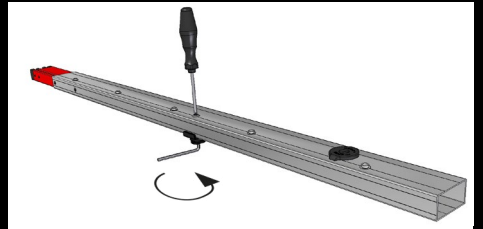

(Picture Vario 64)



AV Stumpfl GmbH | Mitterweg 46 | 4702 Wallern
AVstumpfl@AVstumpfl.com | www.AVstumpfl.com | +43 7249 42811