

## Dimension of the Projection Screen

Service area for motor exchange min. 800mm

connecting cable : length 5m, grey

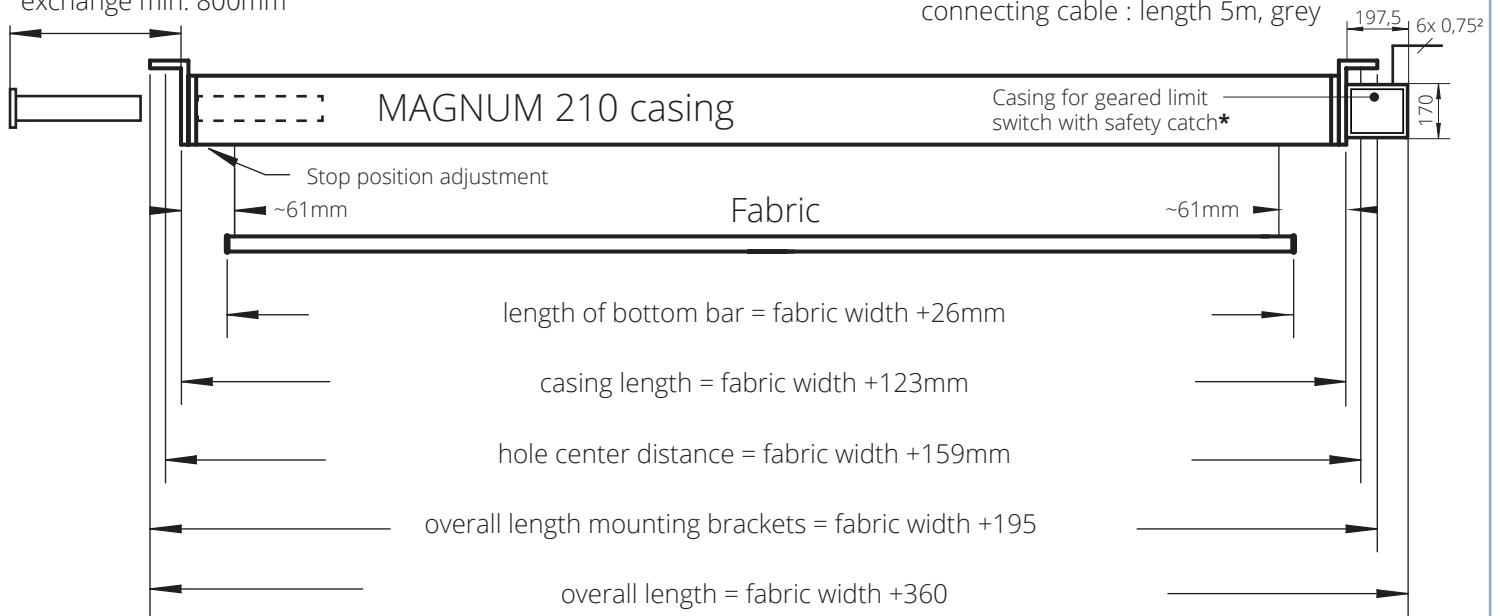

overall length: +/- 5mm

### Cross Section MAGNUM-Casing

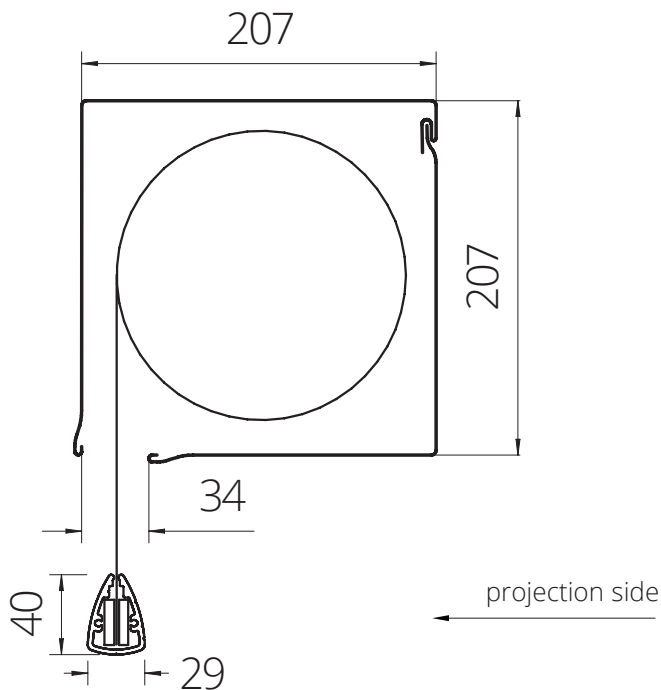

### Universal Mounting Bracket for ceiling mounting

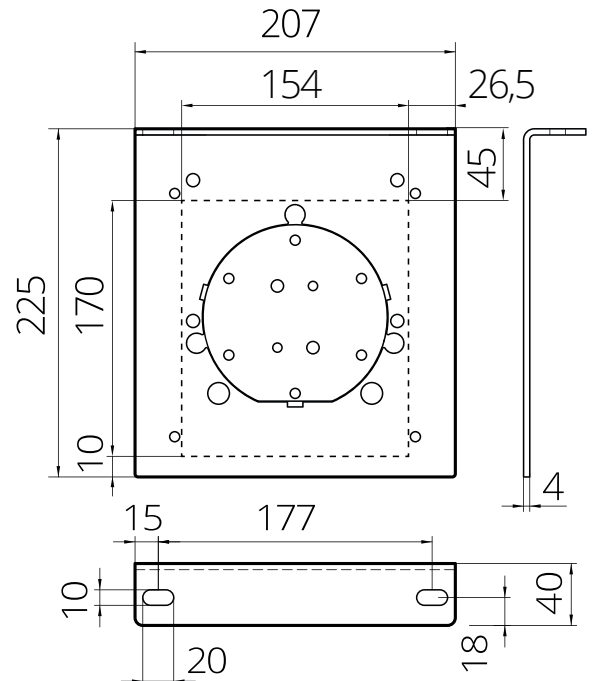

THE BRACKETS OF THE PROJECTION SCREEN MUST BE MOUNTED FORCE-FIT AND POSITIVE-FIT TO THE CEILING CONSTRUCTION ! DO NOT PUT ADDITIONAL MECHANICAL LOAD ON THE CASING ! THE MOUNTING MUST ENSURE THAT NO DISTORTION CAN ARISE !

\* For servicing and adjustment of the geared limit switch and safety catch the casing must be accessible at least from the front and the bottom.