

## Abmessungen der Projektionswand

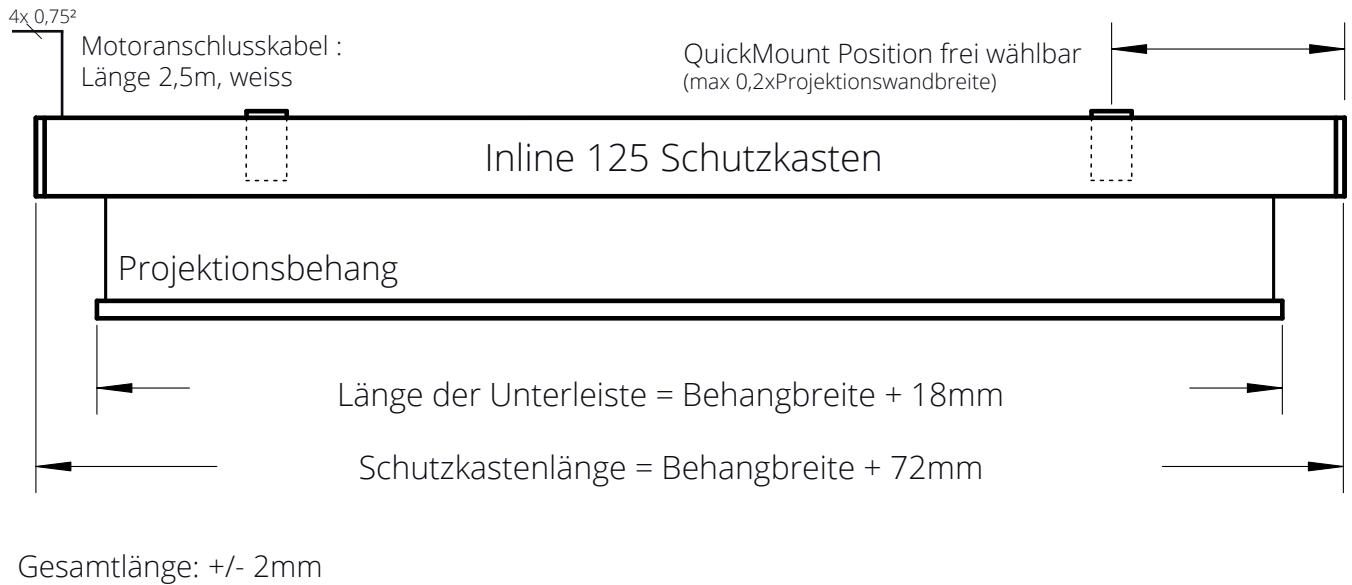

## Querschnitt Inline-QuickMount

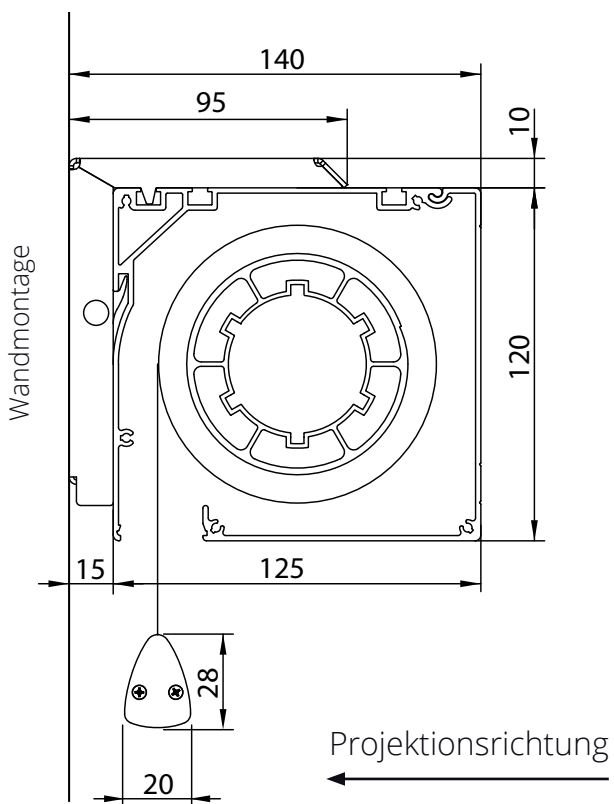

## QuickMount Montagewinkel

für Wand und Deckenmontage

